

MICROPOWER QUAD CMOS VOLTAGE COMPARATORS

- EXTREMELY LOW SUPPLY CURRENT :
9µA TYP / COMPARATOR
- WIDE SINGLE SUPPLY RANGE (3V TO 16V)
OR DUAL SUPPLIES (±1.5V TO ±8V)
- EXTREMELY LOW INPUT BIAS CURRENT :
1pA TYP
- EXTREMELY LOW INPUT OFFSET
CURRENT : 1pA TYP
- INPUT COMMON-MODE VOLTAGE RANGE
INCLUDES GND
- HIGH INPUT IMPEDANCE : 10¹²Ω TYP
- FAST RESPONSE TIME : 1.5µs TYP FOR
5mV OVERDRIVE
- PIN-TO-PIN AND FUNCTIONALLY
COMPATIBLE WITH BIPOLAR LM339

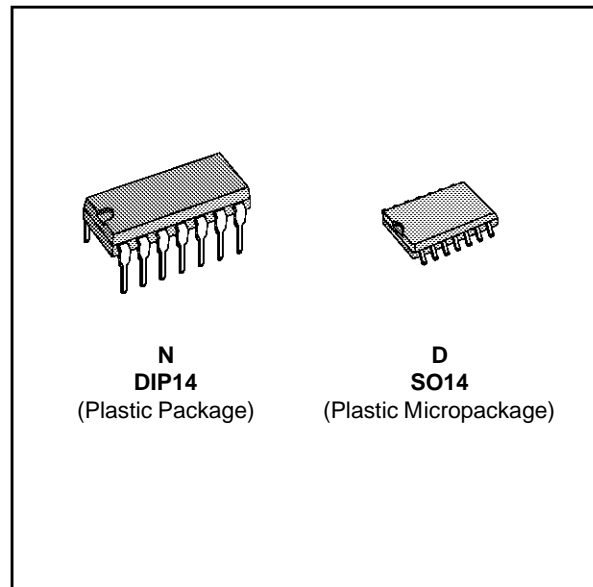

DESCRIPTION

The TS339 is a micropower CMOS quad voltage comparator with extremely low consumption of 9µA typ / comparator (20 times less than bipolar LM339). Similar performances are offered by the quad micropower comparator TS3704 with a push-pull CMOS output.

Thus response times remain similar to the LM339.

ORDER CODES

Part Number	Temperature Range	Package	
		N	D
TS339C	0°C, +70°C	●	●
TS339I	-40°C, +125°C	●	●
TS339M	-55°C, +125°C	●	●
Example : TS339CN			

339-01.TBL

PIN CONNECTIONS (top view)

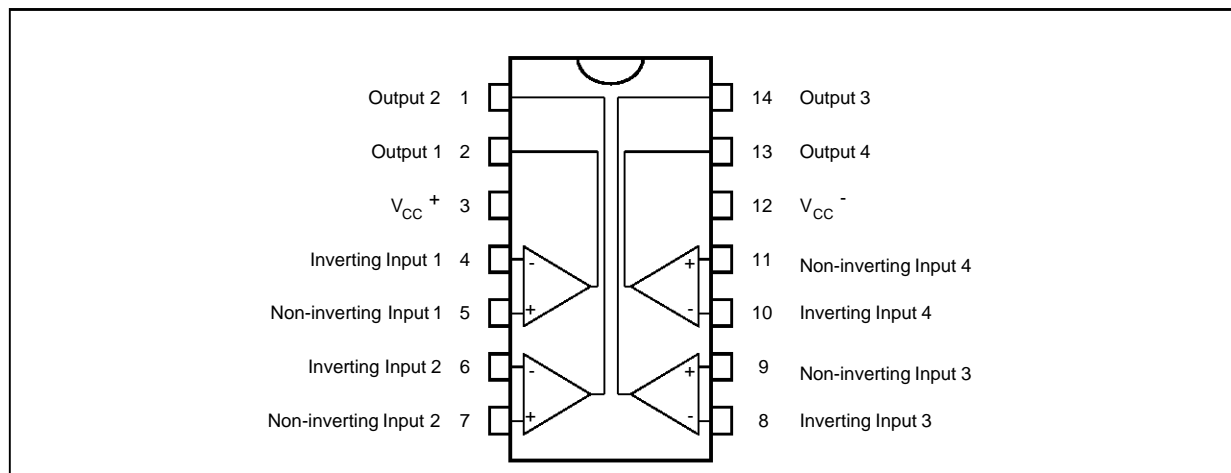

339-01.EPS

SCHEMATIC DIAGRAM (for 1/4 TS339)

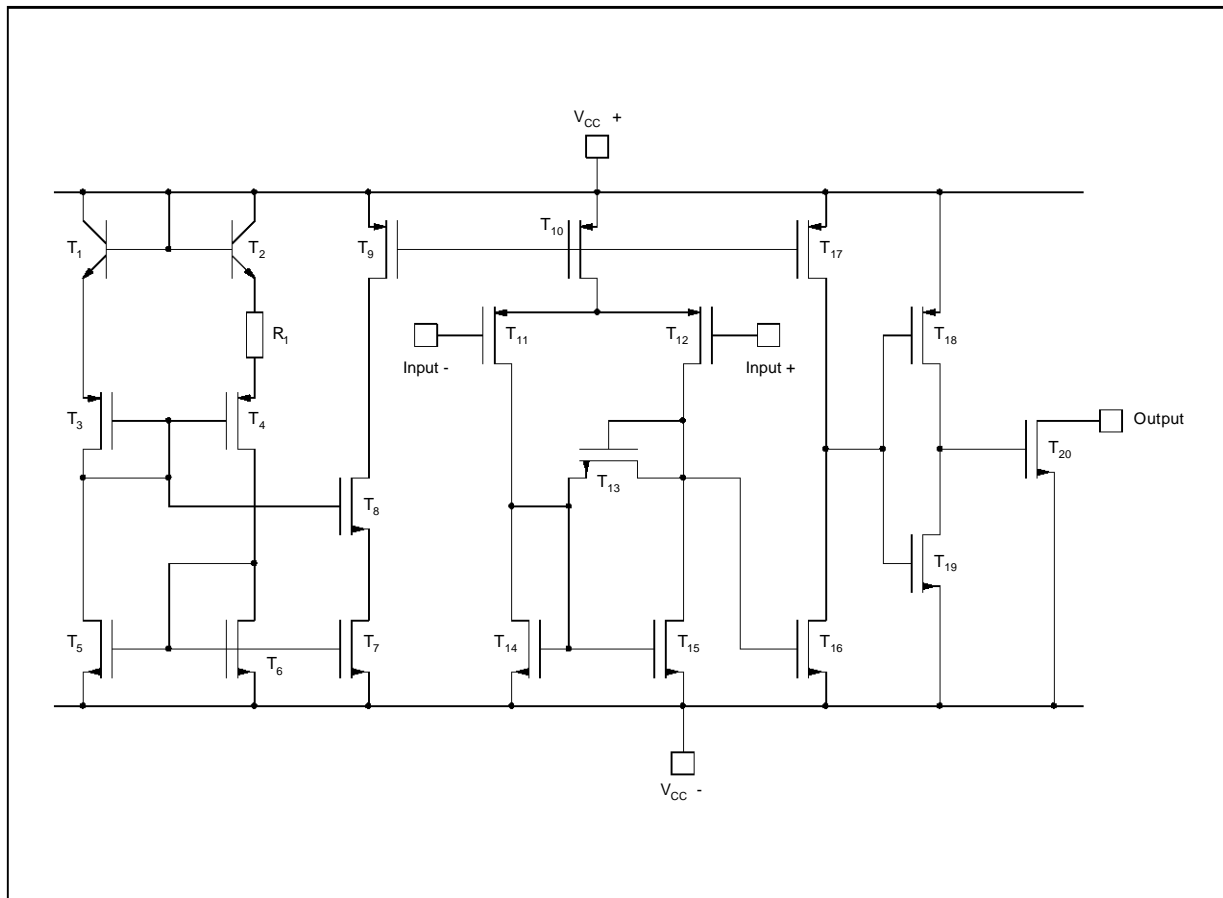

339-02.EPS

MAXIMUM RATINGS

Symbol	Parameter	Value	Unit
V_{CC}^+	Supply Voltage - (note 1)	18	V
V_{id}	Differential Input Voltage - (note 2)	± 18	V
V_i	Input Voltage - (note 3)	18	V
V_O	Output Voltage	18	V
I_O	Output Current	20	mA
T_{oper}	Operating Free-Air Temperature Range	TS339C 0 to +70 TS339I -40 to +125 TS339M -55 to +125	$^{\circ}C$
T_{stg}	Storage Temperature Range	-65 to +150	$^{\circ}C$

339-02.TBL

- Notes :**
- All voltage values, except differential voltage, are with respect to network ground terminal.
 - Differential voltages are the non-inverting input terminal with respect to the inverting input terminal.
 - The magnitude of the input and the output voltages must never exceed the magnitude of the positive supply voltage.
 - Short circuit from outputs to V_{CC}^+ can cause excessive heating and eventual destruction.

OPERATING CONDITIONS

Symbol	Parameter	Value	Unit
V_{CC}^+	Supply Voltage	TS339C,I 3 to 16 TS339M 4 to 16	V
V_{icm}	Common Mode Input Voltage Range	0 to $V_{CC}^+ - 1.5$	V

339-03.TBL

ELECTRICAL CHARACTERISTICS
 $V_{CC}^+ = 5V$, $V_{CC}^- = 0V$, $T_{amb} = 25^\circ C$ (unless otherwise specified)

Symbol	Parameter	Min.	Typ.	Max.	Unit
V_{io}	Input Offset Voltage - (note 1) $V_{ic} = V_{icm\ min.}$, $V_{CC}^+ = 5V$ to $10V$ $T_{min.} \leq T_{amb} \leq T_{max.}$		1.4	5 6.5	mV
I_{io}	Input Offset Current - (note 2) $V_{ic} = 2.5V$ $T_{min.} \leq T_{amb} \leq T_{max.}$		1	300	pA
I_{ib}	Input Bias Current - (note 2) $V_{ic} = 2.5V$ $T_{min.} \leq T_{amb} \leq T_{max.}$		1	600	pA
V_{icm}	Input Common Mode Voltage Range $T_{min.} \leq T_{amb} \leq T_{max.}$	0 to $V_{CC}^+ - 1.2$ 0 to $V_{CC}^+ - 1.5$			V
CMR	Common-mode Rejection Ratio $V_{ic} = V_{icm\ min.}$		75		dB
SVR	Supply Voltage Rejection Ratio $V_{CC}^+ = +5V$ to $+10V$		85		dB
I_{OH}	High Level Output Current $V_{id} = 1V$, $V_{OH} = +5V$ $T_{min.} \leq T_{amb} \leq T_{max.}$		2	40 1000	nA
V_{OL}	Low Level Output Voltage $V_{id} = -1V$, $I_{OL} = 6mA$ $T_{min.} \leq T_{amb} \leq T_{max.}$		350	400 650	mV
I_{CC}	Supply Current (4 comparators) No load - Outputs low $T_{min.} \leq T_{amb} \leq T_{max.}$		36	80 100	μA
t_{PLH}	Response Time Low to High $V_{ic} = 0V$, $f = 10kHz$, $R_L = 5.1k\Omega$, $C_L = 15pF$, Overdrive = 5mV Overdrive = 10mV Overdrive = 20mV Overdrive = 40mV TTL Input		1.5 1.2 1.1 0.9 0.8		μs
t_{PHL}	Response Time High to Low $V_{ic} = 0V$, $f = 10kHz$, $R_L = 5.1k\Omega$, $C_L = 15pF$, Overdrive = 5mV Overdrive = 10mV Overdrive = 20mV Overdrive = 40mV TTL Input		2.5 1.9 1.2 0.8 0.08		μs
t_f	Fall Time $f = 10kHz$, $C_L = 15pF$, $R_L = 5.1k\Omega$, Overdrive 50mV		25		ns

Note : 1. The specified offset voltage is the maximum value required to drive the output up to 4.5V or down to 0.3V.
2. Maximum values including unavoidable inaccuracies of the industrial test.

339-04.TBL

PACKAGE MECHANICAL DATA
14 PINS - PLASTIC DIP

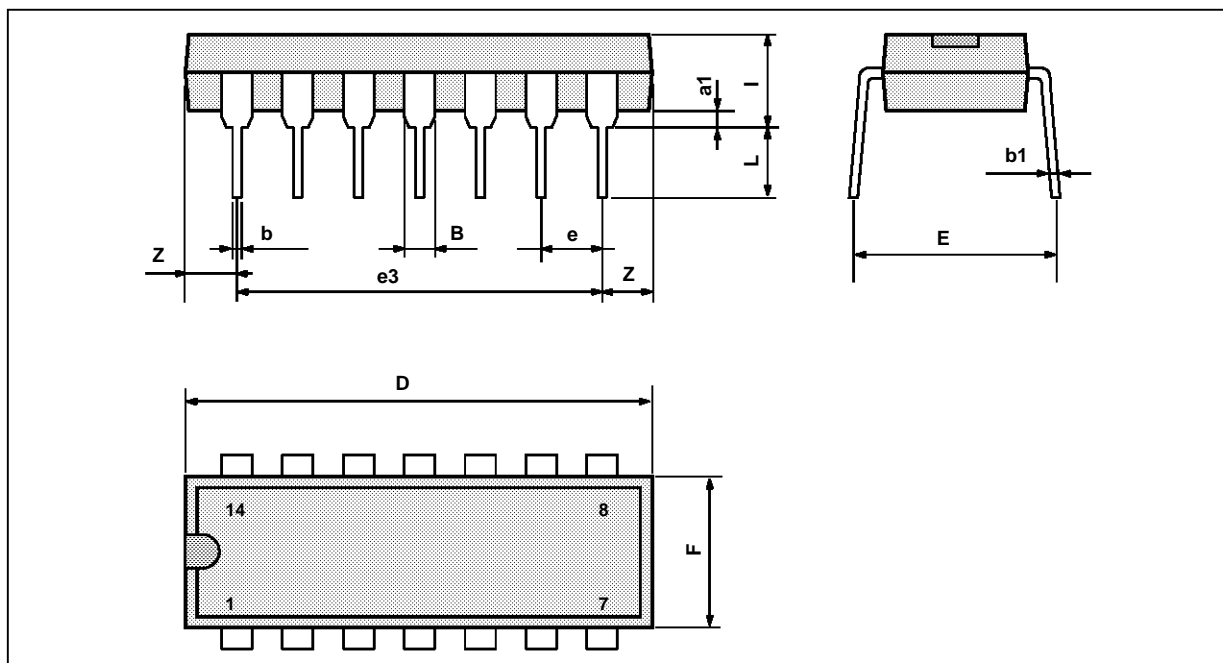

PM-DIP14.EPS

Dimensions	Millimeters			Inches		
	Min.	Typ.	Max.	Min.	Typ.	Max.
a1	0.51			0.020		
B	1.39		1.65	0.055		0.065
b		0.5			0.020	
b1		0.25			0.010	
D			20			0.787
E		8.5			0.335	
e		2.54			0.100	
e3		15.24			0.600	
F			7.1			0.280
i			5.1			0.201
L		3.3			0.130	
Z	1.27		2.54	0.050		0.100

DIP14.TBL

PACKAGE MECHANICAL DATA
14 PINS - PLASTIC MICROPACKAGE (SO)

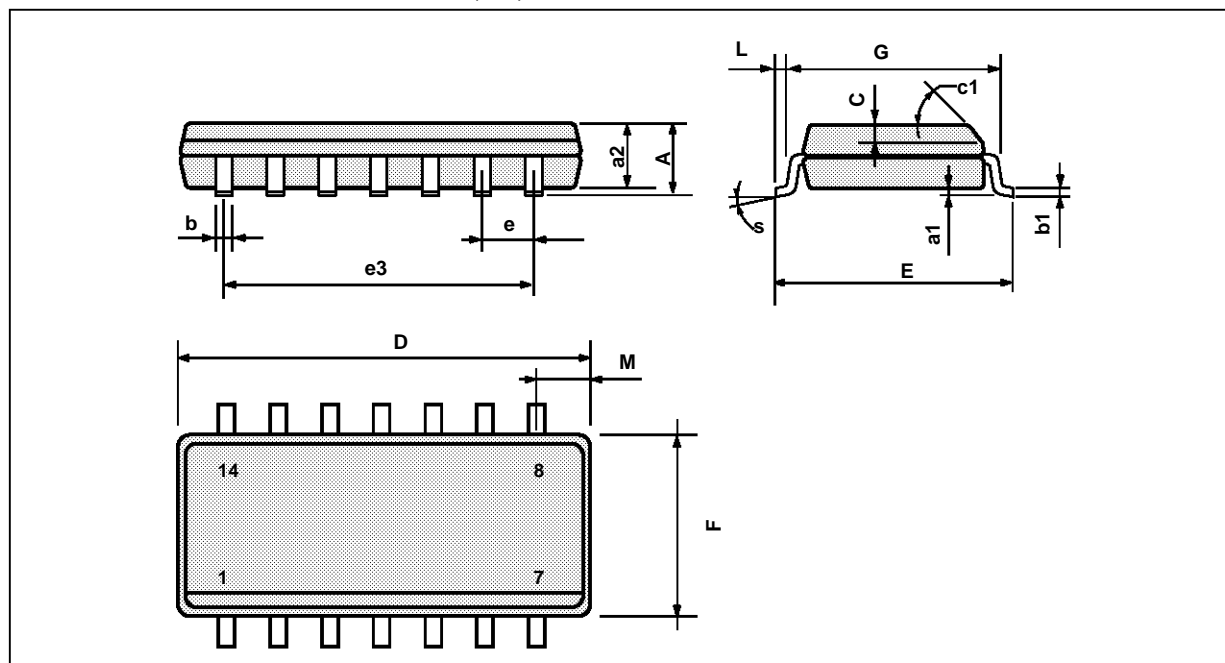

PM-SO14EPS

Dimensions	Millimeters			Inches		
	Min.	Typ.	Max.	Min.	Typ.	Max.
A			1.75			0.069
a1	0.1		0.2	0.004		0.008
a2			1.6			0.063
b	0.35		0.46	0.014		0.018
b1	0.19		0.25	0.007		0.010
C		0.5			0.020	
c1	45° (typ.)					
D	8.55		8.75	0.336		0.334
E	5.8		6.2	0.228		0.244
e		1.27			0.050	
e3		7.62			0.300	
F	3.8		4.0	0.150		0.157
G	4.6		5.3	0.181		0.208
L	0.5		1.27	0.020		0.050
M			0.68			0.027
S	8° (max.)					

SO14.TBL

Information furnished is believed to be accurate and reliable. However, SGS-THOMSON Microelectronics assumes no responsibility for the consequences of use of such information nor for any infringement of patents or other rights of third parties which may result from its use. No licence is granted by implication or otherwise under any patent or patent rights of SGS-THOMSON Microelectronics. Specifications mentioned in this publication are subject to change without notice. This publication supersedes and replaces all information previously supplied. SGS-THOMSON Microelectronics products are not authorized for use as critical components in life support devices or systems without express written approval of SGS-THOMSON Microelectronics.

© 1995 SGS-THOMSON Microelectronics - All Rights Reserved

SGS-THOMSON Microelectronics GROUP OF COMPANIES

Australia - Brazil - France - Germany - Hong Kong - Italy - Japan - Korea - Malaysia - Malta - Morocco - The Netherlands
Singapore - Spain - Sweden - Switzerland - Taiwan - Thailand - United Kingdom - U.S.A.

ORDER CODE :